

1、 Features:

- Emitting Color: White
- Lens Type: Yellow Diffused
- Device Outline: 5.7×3.0×0.90 (unit:mm)
- RoHS compliant

2、 Applications:

- Backlight for Mobile, Machine Vision, LCD Display
- Backlight in Dashboard and switch of Automotive
- Indoor Lighting

3、 Outline Dimensions:

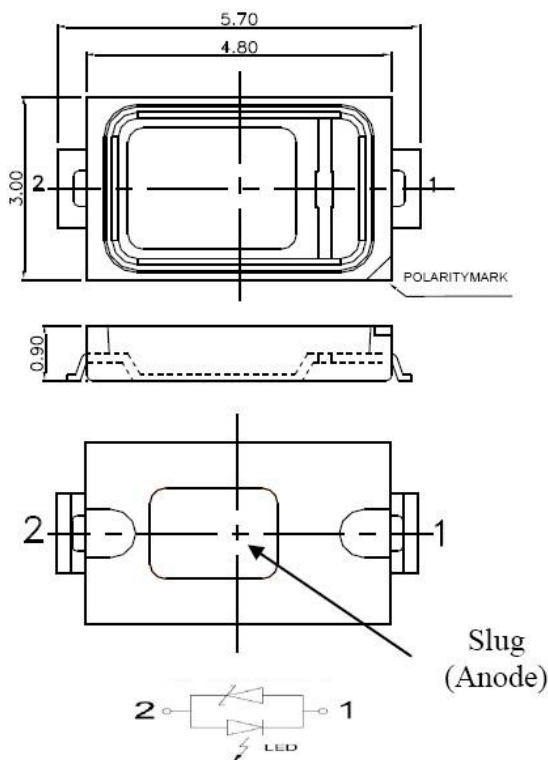

Recommended Soldering Pattern:

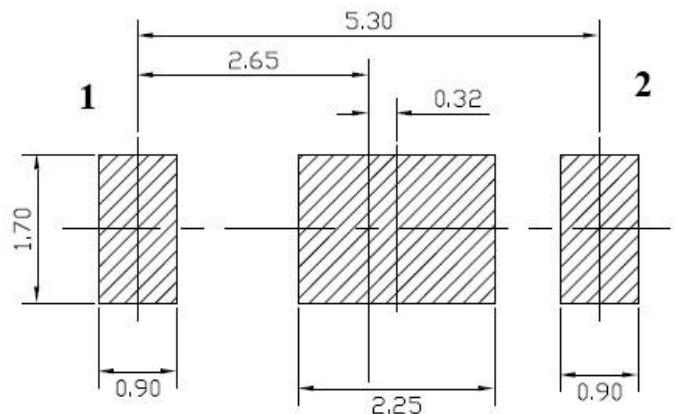

Note: 1.All dimension units are millimeters

2. All dimension tolerance is $\pm 0.15\text{mm}$

4、 Absolute maximum ratings (Ta = 25°C):

Parameter	Symbol	Test Condition	Value		Unit
			Min.	Max.	
Power Dissipation	Pd	---	---	650	mW
Reverse Voltage	VR	IR = 30 μA	5	---	V
Pulse Current	IFp	Duty=0.1, 1kHz	---	200	mA
Forward Current	IFm	---	---	150	mA
Operating Temperature	Topr	---	-40	+85	°C
Storage Temperature	Tstr	---	-40	+100	°C

5、 Electrical and optical characteristics (Ta = 25°C):

Parameter	Symbol	Test Condition	Value			Unit
			Min.	Typ.	Max.	
Forward Voltage	VF	IF = 150mA	3.0	---	3.5	V
Reverse Current	IR	VR = 5V	---	---	30	μA
Color Temperature	Tc	IF = 150mA	---	6000	---	K
Luminous Flux	Iv	IF = 150mA	50	55	60	lm
Color Rendering index	Ra	IF = 150mA	80	---	---	---
Viewing Angle	2 θ 1/2	IF = 150mA	---	120	---	Deg.

6、Typical electrical/optical characteristic curves/光电特性曲线:

