

1、 Features:

- Emitting Color: Red
- Lens Type: Water Clear
- Device Outline: 5.0x5.0x1.5 (unit:mm)
- RoHS compliant

2、 Applications:

- Backlight for Mobile, Machine Vision, LCD Display
- Backlight in Dashboard and switch of Automive
- Indoor LED lighting, Architectural Lighting

3、 Outline Dimensions:

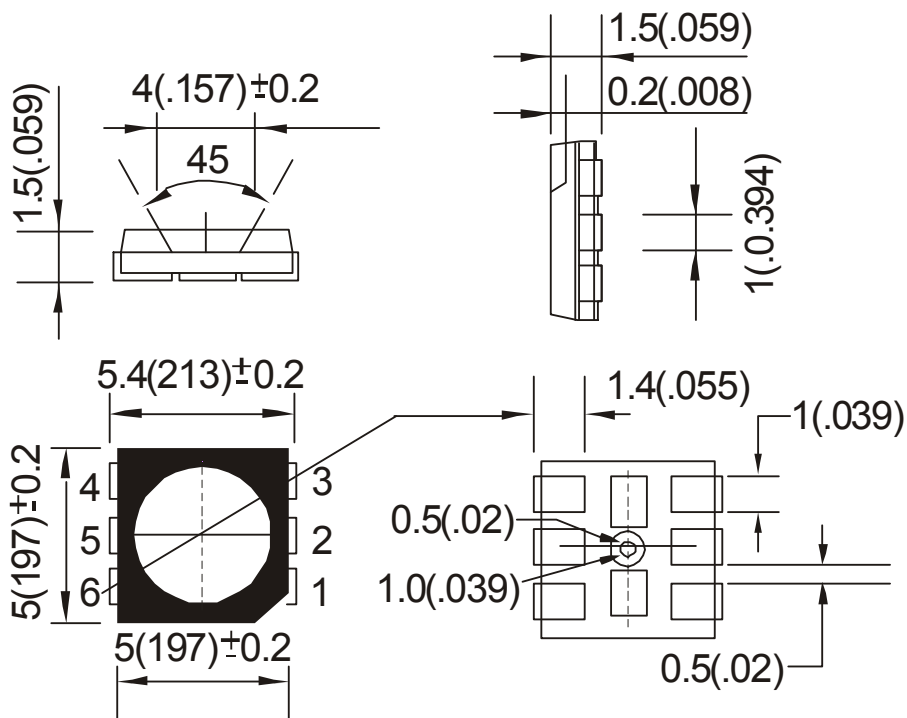



4、 Absolute maximum ratings (Ta = 25°C):

Parameter	Symbol	Test Condition	Value		Unit
			Min.	Max.	
Power Dissipation	Pd	—	—	180	mW
Reverse Voltage	VR	IR = 30 μA	5	—	V
Pulse Current	IFp	Duty=0.1, 1kHz	—	100	mA
Forward Current	IFm	—	—	25	mA
Operating Temperature	Topr	—	-40	+85	°C
Storage Temperature	Tstr	—	-40	+100	°C

5、 Electrical and optical characteristics (Ta = 25°C):

Parameter	Symbol	Test Condition	Value			Unit
			Min.	Typ.	Max.	
Forward Voltage	VF	IF = 60mA	1.8	—	2.6	V
Reverse Current	IR	VR = 5V	—	—	30	μA
Wavelength	Tc	IF = 60mA	619	624	629	nm
Luminous Intensity	Iv	IF = 60mA	1200	1600	2000	mcd
Viewing Angle	2θ 1/2	IF = 60mA	—	120	—	Deg.

6. Typical electrical/optical characteristic curves:

Fig.1

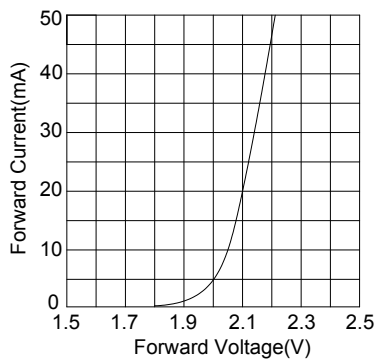

Fig.2

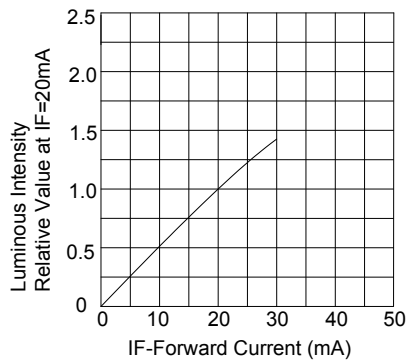

Fig.3

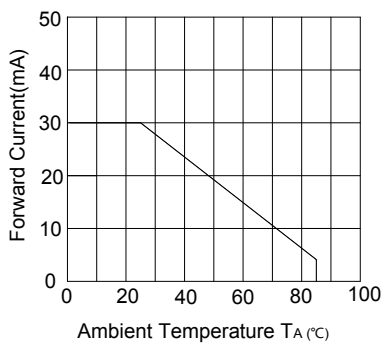

Fig.4

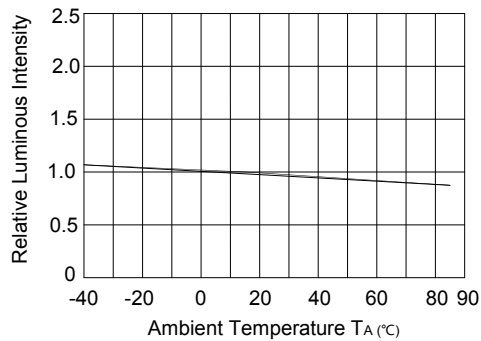

Fig.5

