



Part No.: **JSL-502WWC-30**

Features:

- Single color
- High bright output
- Low power consumption
- High reliability and long life

Descriptions:

- Dice material: AlGaInP
- Emitting Color: Super Bright Warm White
- Device Outline: ϕ 5mm Round Type
- Lens Type: Water Clear

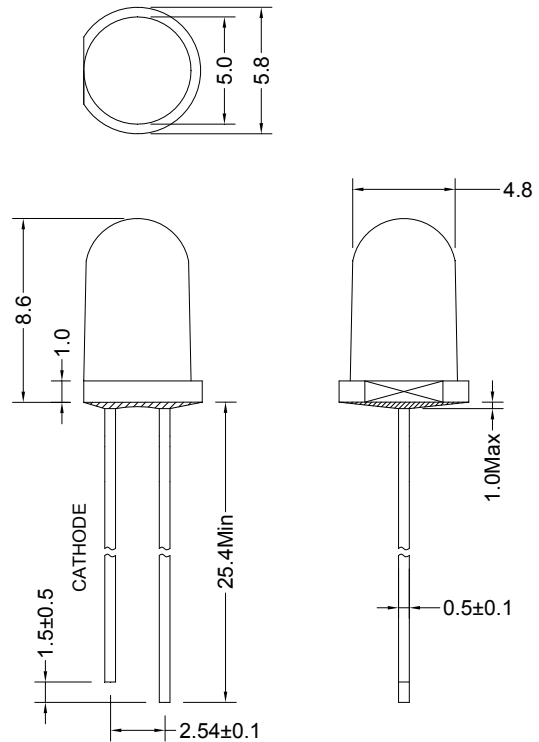

1. All dimensions are millimeters
2. Tolerance is ± 0.20 mm unless otherwise noted

Directivity:

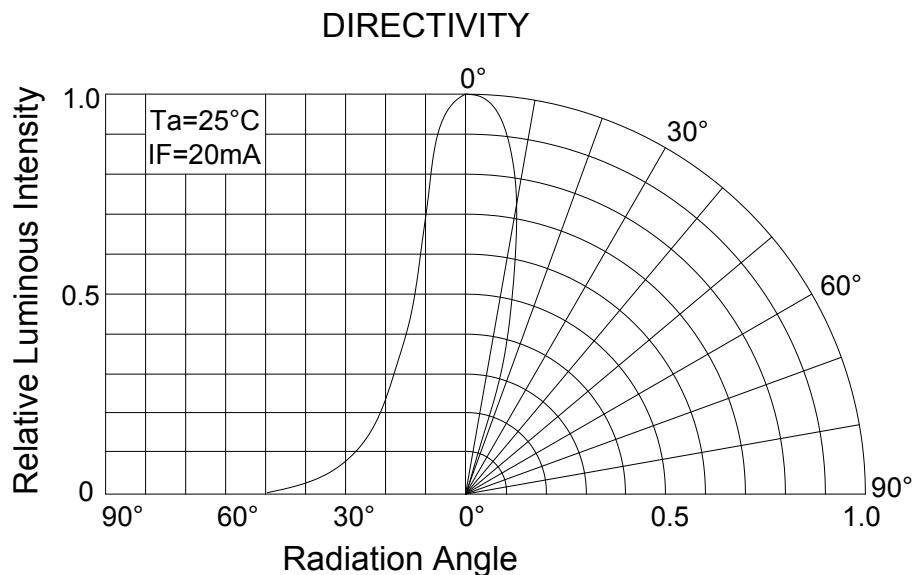



Part No.: JSL-502WWC-30

Absolute maximum ratings (Ta = 25°C)

Parameter	Symbol	Test Condition	Values		Unit
			Min.	Max.	
Reverse Voltage	V _R	I _R = 30 μ A	5	--	V
Forward Current	I _F	----	----	30	mA
Power Dissipation	P _d	----	----	75	mW
Pulse Current	I _{peak}	Duty=0.1mS, 1kHz	----	100	mA
Operating Temperature	T _{opr}	----	-40	+85	°C
Storage Temperature	T _{str}	----	-40	+100	°C

Electrical and optical characteristics (Ta = 25°C)

Parameter	Symbol	Test Condition	Values			Unit
			Min.	Typ.	Max.	
Forward Voltage 正向电压	V _F	I _F =20mA	----	3.2	3.6	V
Reverse Current	I _R	V _R =5V	----	----	30	μ A
Color Temperature	T _c	I _F = 20mA	----	3000	----	K
Luminous Intensity	I _v	I _F =20mA	10000	15000	20000	mcd
Viewing Angle	2 θ 1/2	I _F =20mA	----	26	30	deg.



Part No.: JSL-502WWC-30

Typical electrical/optical characteristic curves:

