



Part No.: JSL-1880UWC-90

Features:

- Single color
- High bright output
- Low power consumption
- High reliability and long life

Descriptions:

- Dice material: AlGaInP
- Emitting Color: Super Bright White
- Device Outline: ϕ 5mm LED Flux
- Lens Type: Water Clear

Package dimension:

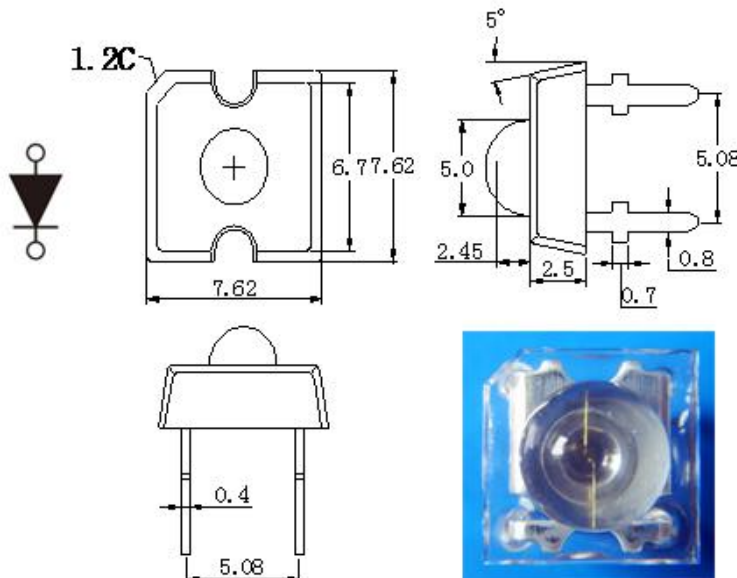

NOTES:

- 1.All dimensions are in millimeters (inches).
- 2.Tolerance is $\pm 0.10\text{mm}$ (0.004") unless otherwise specified.



Part No.: JSL-1880UWC-90

Absolute maximum ratings (Ta = 25°C)

Parameter	Symbol	Test Condition	Values		Unit
			Min.	Max.	
Reverse Voltage	V _R	I _R = 30 μ A	5	--	V
Forward Current	I _F	----	----	30	mA
Power Dissipation	P _d	----	----	75	mW
Pulse Current	I _{peak}	Duty=0.1mS, 1kHz	----	100	mA
Operating Temperature	T _{opr}	----	-40	+85	°C
Storage Temperature	T _{str}	----	-40	+100	°C

Electrical and optical characteristics (Ta = 25°C)

Parameter	Symbol	Test Condition	Values			Unit
			Min.	Typ.	Max.	
Forward Voltage 正向电压	V _F	I _F =20mA	----	3.2	3.4	V
Reverse Current	I _R	V _R =5V	----	----	30	μ A
Color Temperature	λ _d	I _F =20mA	6000	6500	7000	K
Luminous Intensity	I _v	I _F =20mA	3000	3500	4000	mcd
Viewing Angle	2 θ 1/2	I _F =20mA	----	90	----	deg.



Part No.: JSL-1880UWC-90

Typical electrical/optical characteristic curves:

典型的光-电曲线图:

Forward Current vs. Ambient Temperature

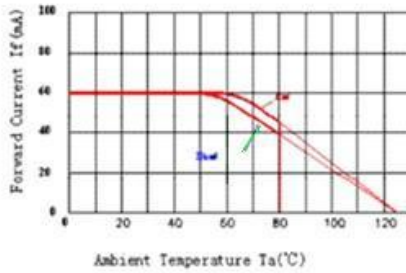

Relative Intensity IV (mcd) vs. Ambient Temperature

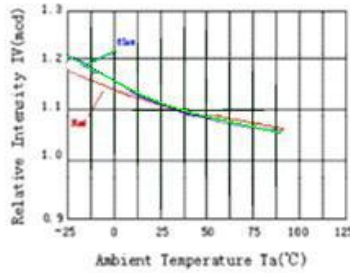

Forward Current vs. Forward Voltage

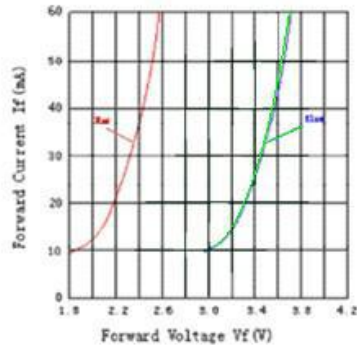

Forward Voltage VF (V) vs. Ambient Temperature

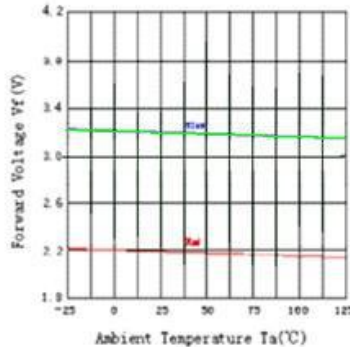

50% Power Angle: 115°

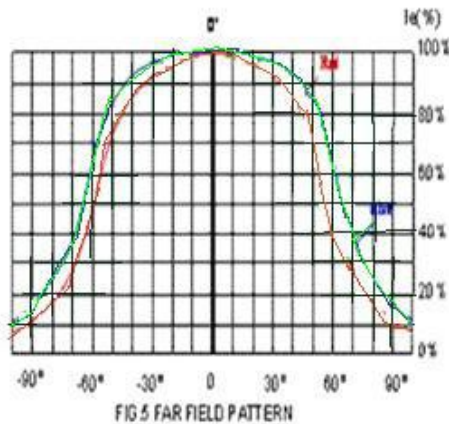

Luminous Spectrum (Ta=25°C) SPECTRAL RADIANCE

