

Part No.: JSLs-3W-UP

Features:

- Highest Flux
- High reliability and Very long operating life (up to 100K hours)
- Low voltage DC operated
- More Energy Efficient than Incandescent and most Halogen lamps
- NO UV
- Superior ESD protection

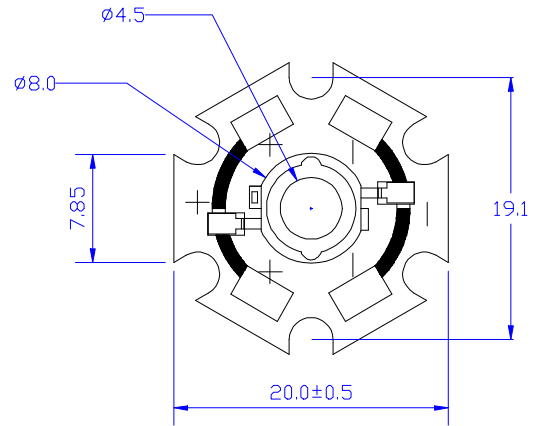

Typical Applications:

- Growing lights
- Vegetable Lighting

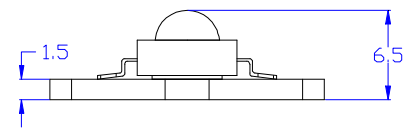

NOTE:

- All dimensions are millimeter.
- Tolerance is $\pm 0.25\text{mm}$ unless otherwise noted

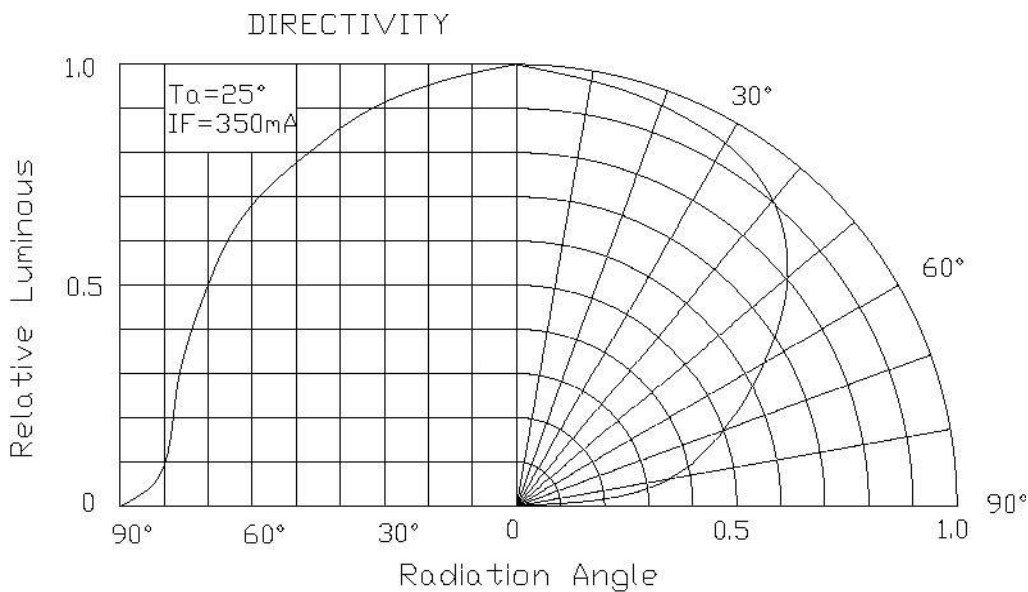



Ningbo Junsheng Electronics Co.,LTD.

Part No.: **JSL5-3W-UP**

Absolute maximum ratings (Ta = 25°C)

Parameter	Symbol	Test Condition	Value		Unit
			Min.	Max.	
DC Forward Current	IF	----	----	700	mA
Peak Pulse Current	Ipeak	Duty=0.1, 1kHz	----	1000	mA
Power Dissipation	Pd	----	----	3.0	W
LED Junction Temperature	Tj	----	----	120	°C
Operating Temperature	Topr	----	-25	+100	°C
Storage Temperature	Tstr	----	-40	+120	°C
ESD Sensitivity	---	HBM	8000	----	V
Soldering Temperature	---	----	260°C for 5 Seconds max		

Electrical and optical characteristics (Ta = 25°C)

Parameter	Symbol	Test Condition	Value			Unit
			Min.	Typ.	Max.	
Forward Voltage	VF	IF = 700mA	3.0	----	3.6	V
Luminous Flux	Φv	IF = 700mA	120	----	150	lm
Viewing Angle	2θ 1/2	IF = 700mA	----	120	----	Deg.
Color Temperature	CCT	IF = 700mA	2000	----	2400	K

Typical Electro-Optical Characteristics Curves

