

Part No.: JSL-5W-UR620

Features:

- Highest Flux Red
- High reliability and Very long operating life
 - (up to 100K hours)
 - Low voltage DC operated
 - More Energy Efficient than Incandescent and most Halogen lamps
- NO UV
- Superior ESD protection

Typical Applications:

- Reading lights(car,bus,aircraft)
- Portable(flashlight,bicycle)
- Automotive Exterior(Stop-Tail-Turn, CHMSL,Mirror Side Repeat)
- Decorative

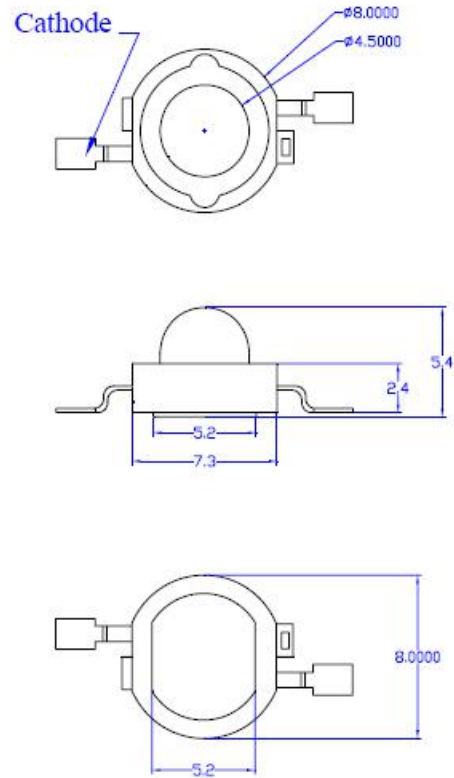

NOTE:

- All dimensions are millimeter.
- Tolerance is $\pm 0.25\text{mm}$ unless otherwise noted

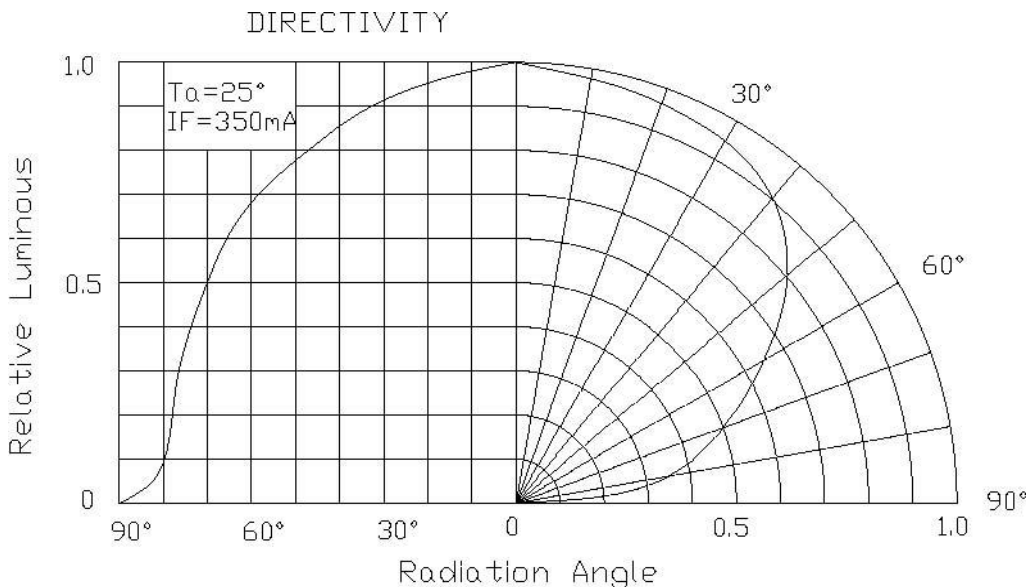

Absolute maximum ratings (Ta = 25°C)

Parameter	Symbol	Test Condition	Value		Unit
			Min.	Max.	
DC Forward Current	IF	----	----	1400	mA
Peak Pulse Current	Ipeak	Duty=0.1, 1kHz	----	2000	mA
Power Dissipation	Pd	----	----	5	W
LED Junction Temperature	Tj	----	----	120	°C
Operating Temperature	Topr	----	-25	+100	°C
Storage Temperature	Tstr	----	-40	+120	°C
ESD Sensitivity	---	HBM	8000	----	V
Soldering Temperature	---	----	260°C for 5 Seconds max		

Electrical and optical characteristics (Ta = 25°C)

Parameter	Symbol	Test Condition	Value			Unit
			Min.	Typ.	Max.	
Forward Voltage	VF	IF = 1400mA	2.4	----	2.8	V
Luminous Flux	Φv	IF = 1400mA	120	150	----	lm
Viewing Angle	2θ 1/2	IF = 1400mA	----	140	----	Deg.
Dominate Wavelength	λd	IF = 1400mA	620	----	630	nm
Reverse Current	IR	VR=5V			20	uA



Typical Electro-Optical Characteristics Curves

Fig.1 Relative intensity Vs. Wavelength

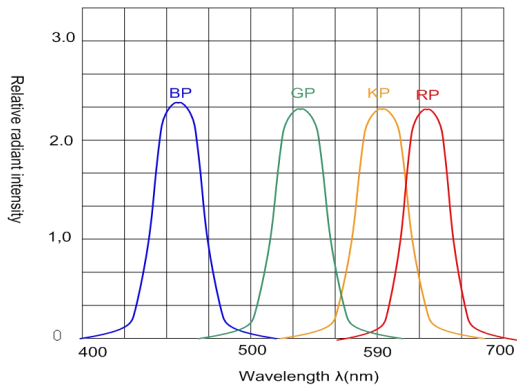

Fig.2 Forward current Vs. Forward voltage

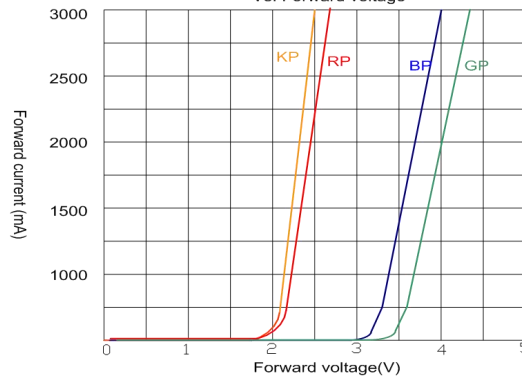

Fig.3 Relative luminous intensity Vs. Forward current

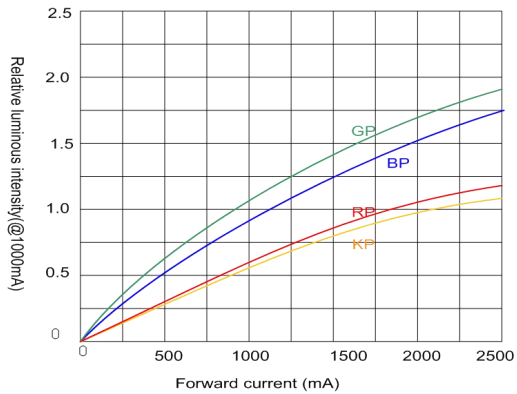

Fig.4 Radiation diagram

