

# Ningbo Junsheng Electronics Co.,LTD.

## 产品承认书

### PRODUCT APPROVED

(CUSTOMERS) \_\_\_\_\_

(CUSTOMER P/N) \_\_\_\_\_

(PART NUMBER) JSS-4021Bxx

(DESCRIPTION) 0.4 inch common anode 14 segmnet smd display

(SAMPLE DATE) \_\_\_\_\_

Specification	INSPECTION	SAMPLE	OTHERS
(APPROVED BY)	(CHECKED BY)	(PROOFREAD BY)	(PREPARED BY)

Version	Date	Description	Maker

### (CUSTOMER VERDICT)

(OK)

(NG)

(APPROVED BY):

(APPROVED DATE):

(IMPROVED ADVICE):

**REMARK:** FOR OFFERING THE BEST SERVICE TO CUSTOMER, PLEASE FAX THE DATA TO FACTORY IN TIME



## 4.INTERNAL CIRCUIT DIAGRAM

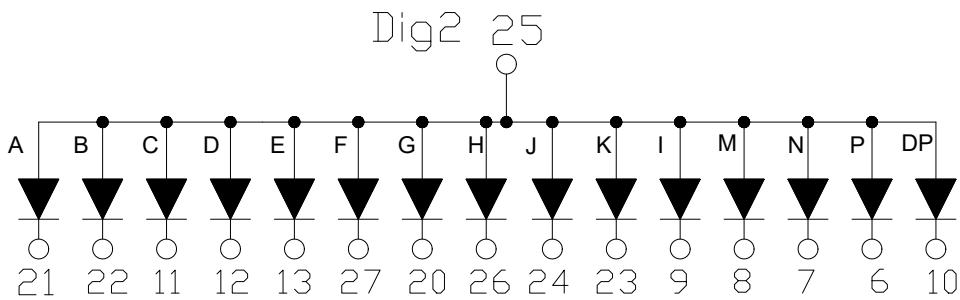
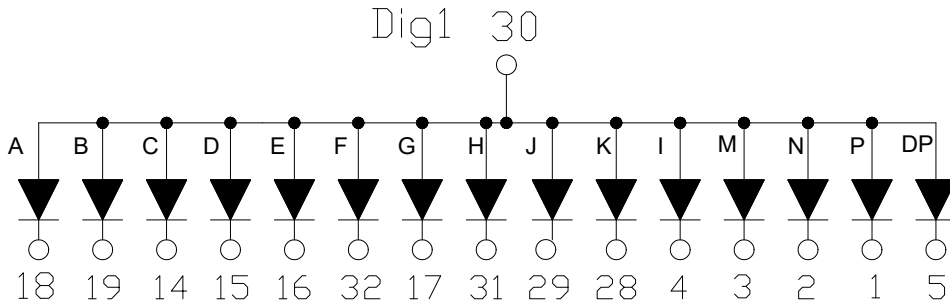
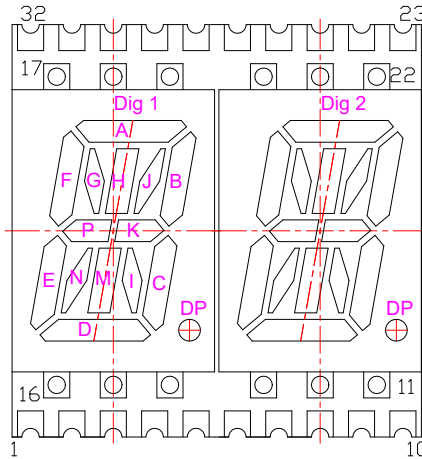



## 5.ABSOLUTE MAXIMUM RATINGS AT T<sub>a</sub>=25°C:

Items	Symbol	Absolute maximum Rating	Unit
Forward Current(DC)	IF	20	mA
Power Dissipation	W	60	Mw
Peak Forward Current*	IFP	100	mA
Reverse Voltage	VR	5	V
Operation Temperature	Topr	-40+85	°C
Storage Temperature	Tstg	-40+100	°C
Lead Soldering Temperature	Tsol	Max .260 °C for 3 sec Max. (3mm from the base of the epoxy bulb)	

## 6.ELECTRICAL/OPTICAL CHARACTERISTICS AT Ta=25°C:

Part No	Emitting Color	Chip Material	Forward Voltage (V)		Luminous Intensity (mcd)		Peak Wave Length(λP) nm	
			Typ	Max	Min	Typ	Typ	Max
Common Anode			IF=10mA					
JSS-4021BUR-21	Ultra Red	AlGaN <sub>3</sub> P	2.0	2.5	20	40	630	640
JSS-4021BSR-21	Super Red	AlGaN <sub>3</sub> P	2.0	2.5	40	80	620	625
JSS-4021BUY-21	Yellow	AlGaN <sub>3</sub> P	2.0	2.5	40	60	585	595
JSS-4021BUG-21	Green	AlGaN <sub>3</sub> P	2.0	2.5	10	20	570	575
JSS-4021BUA-21	Amber	AlGaN <sub>3</sub> P	2.0	2.5	40	60	600	610
JSS-4021BUB-21	Blue	InGaN	3.0	3.5	40	60	460	470
JSS-4021BPG-21	Pure Green	InGaN	3.0	3.5	80	150	520	525
JSS-4021BUW-21	White	InGaN	3.0	3.5	100	200	X0.30/Y0.30	

## 7.Recommended Soldering Pattern:

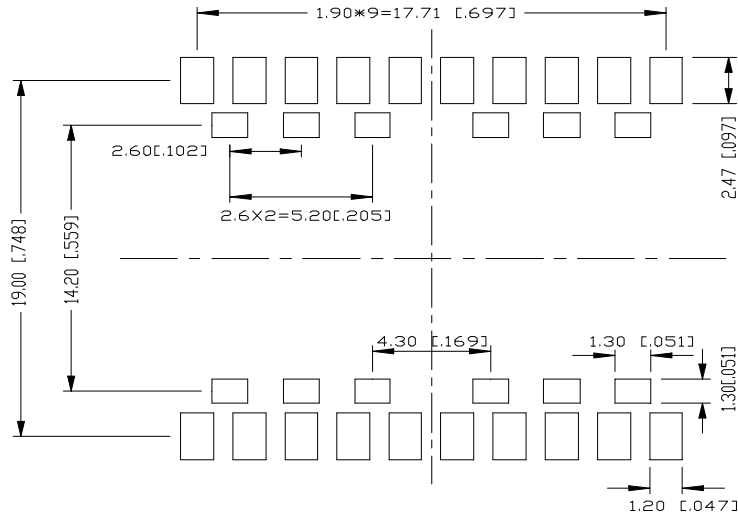

## 8、推荐的 SMT 焊接曲线 Recommended SMT condition:

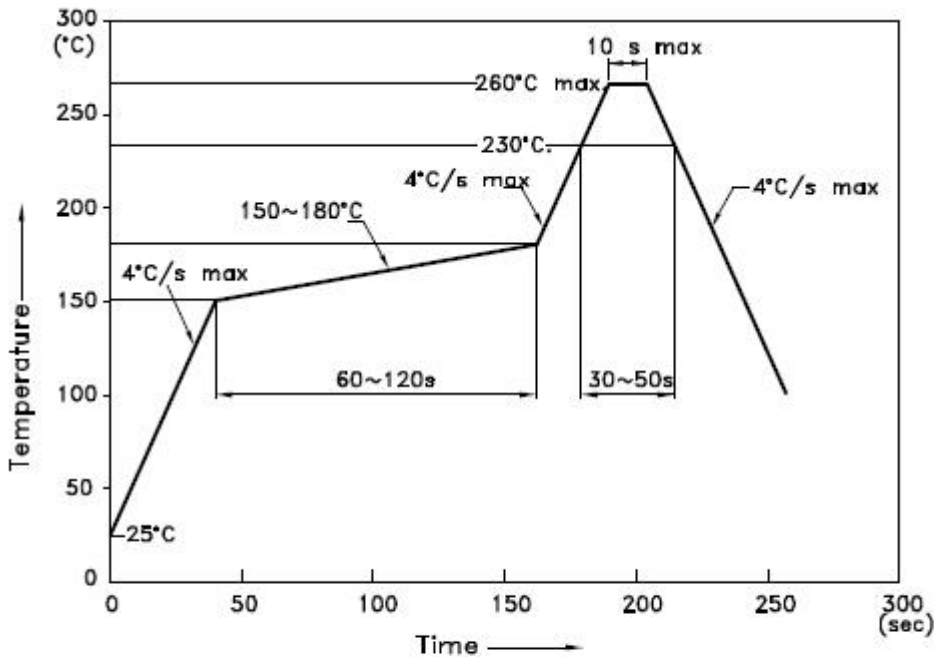

### NOTES:

- 1.We recommend the reflow temperature 245°C(+/-5°C).The maximum soldering temperature should be limited to 260°C.
- 2.Don't cause stress to the epoxy resin while it is exposed to high temperature.
- 3.Number of reflow process shall be 2 times or less.