



Ningbo Junsheng Electronics Co.,LTD.

Part No: JSL-1880UYC

Features:

- Single color
- High bright output
- Low power consumption
- High reliability and long life

Descriptions

- Super Flux LED Lamp
- Emitting Color: Super Bright Yellow
- Device Outline: Square(7.62mm x 7.62mm) with 5mm dome
- Lens Type: Water Clear

Application:

- Automotive lighting.
- Electronic signs and signals.
- Special Lighting Application

Package Dimension:

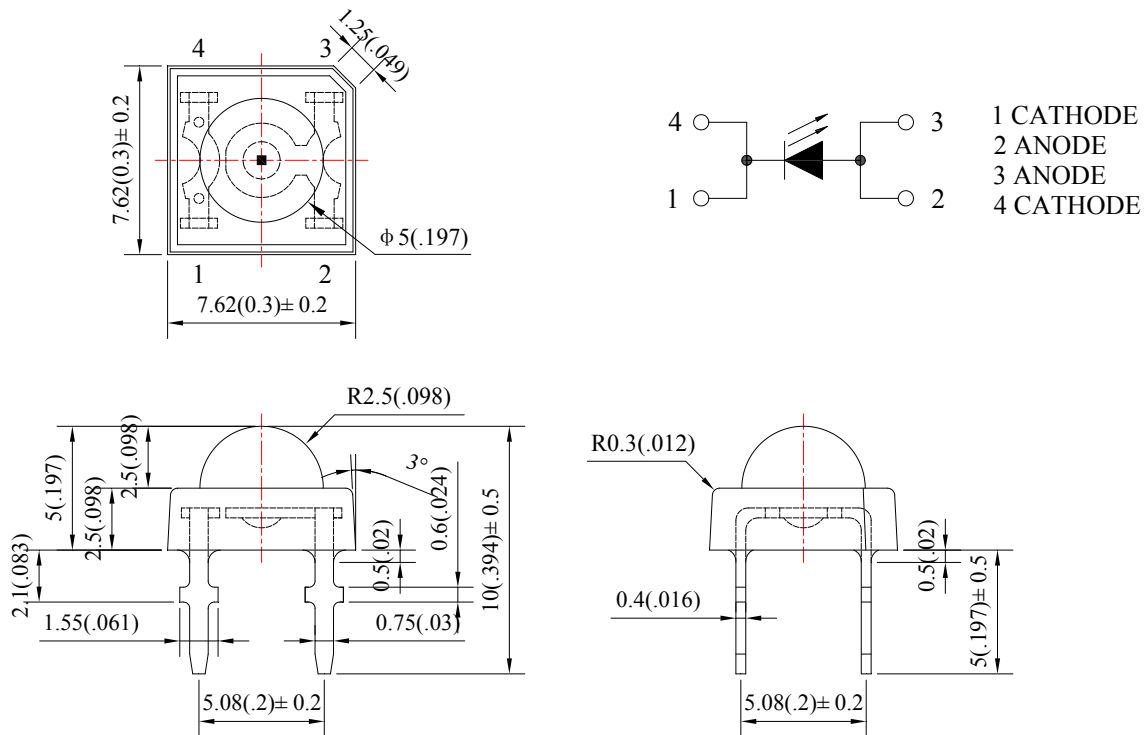

Notes:

1. All dimensions are millimeters/单位: mm.
2. Tolerance is ± 0.25 mm unless otherwise noted/
没有标注的公差均为 ± 0.25 mm



Ningbo Junsheng Electronics Co.,LTD.

Part No: **JSL-1880UYC**

Absolute maximum ratings (Ta = 25°C)

Parameter	Symbol	Test Condition	Values		Unit
			Min.	Max.	
Reverse Voltage	V _R	I _R = 30 μA	5	--	V
Forward Current	I _F	----	----	30	mA
Power Dissipation	P _d	----	----	75	mW
Pulse Current	I _{peak}	Duty=0.1mS, 1kHz	----	100	mA
Operating Temperature	T _{opr}	----	-40	+85	°C
Storage Temperature	T _{str}	----	-40	+100	°C

Electrical and optical characteristics (Ta = 25°C)

Parameter	Symbol	Test Condition	Values			Unit
			Min.	Typ.	Max.	
Forward Voltage	V _F	I _F =20mA	1.9	2.1	2.4	V
Reverse Current	I _R	V _R =5V	----	----	30	μA
Dominate Wavelength	λ _d	I _F =20mA	----	590	----	nm
Peak Wavelength	λ _p	I _F =20mA	----	592	----	nm
Spectral Line half-width	Δλ	I _F =20mA	----	15	----	nm
Luminous Intensity	I _v	I _F =20mA	1000	1500	----	mcd
Viewing Angle	2θ _{1/2}	I _F =20mA	----	90	----	deg.

Typical electrical/optical characteristic curves:

Fig.1 正向电流 Vs. 正向电压

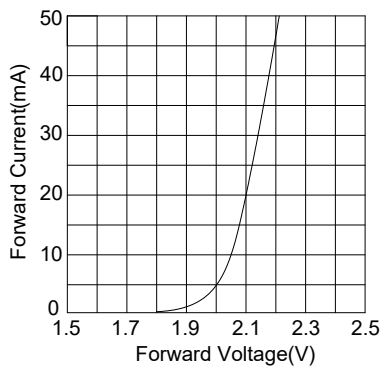

Fig.2 相对亮度 Vs. 正向电流

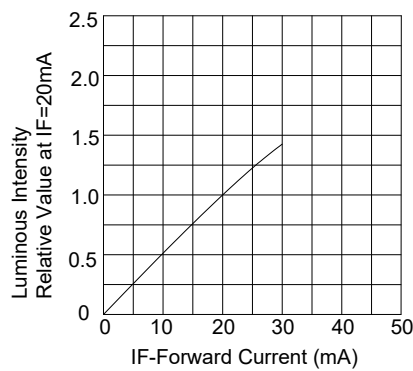

Fig.3 正向电流 Vs. 环境温度

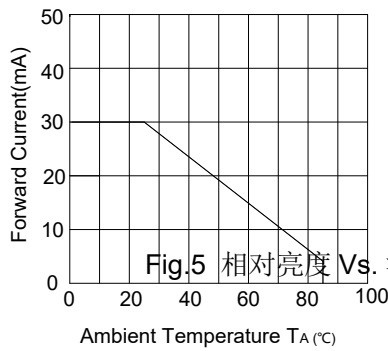

Fig.4 相对亮度 Vs. 环境温度

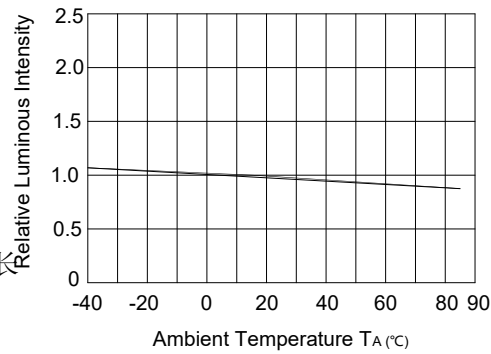

Fig.5 相对亮度 Vs. 波长

